

Model-M107E

1310nm Optical Transmitter

User's Manual



1. Introduction

Model M107E Optical Transmitter is a new product developed by Shanghai Qianjin Electronics Equipment Co., Ltd. The Appearance of the chassis features LCD display, thin film switch, finger-mark-free steel plate, and a vivid color, which make the unit look elegant and modern. M107E is one intelligent standard 19" 1RU chassis and can be monitored by the network management software, in this way, the network management software can get clear status of the set.

M107E optical transmitter has totally 10 output powers including 8, 10, 12, 14, 16, 18, 20, 22, 24 and 26dBm, . (Refer to the Ordering Information below) it uses an internal isolated Distributed Feedback (DFB) laser, which represents the latest technology. Its high cost-effective and wonderful performance are highlighted by its advanced pre-distortion correction circuit, RF pre-amplifier circuit, high reliability of power supply, intelligent and efficient element management, and unique air- flow design.

2. Features

- 45~860MHz bandwidth;
- High-performance DFB laser to increase the signal quality in HFC;
- Low noise, low distortion and pre-AMP to meet low RF input signal;
- Incorporating circuit design built with RF AMP and pre-distortion correction, enhance equipment distortion specification;
- Elective AGC (Automatic Gain Control) and field MGC (Manual Gain Control) enables superior link optimization and variable modulation depth (RF drive level)
- Effective RF overdrive protection for LD alarm and automatic LD shutdown;
- Effective ATC(Automatic Temperature Control) and APC(Automatic Power Control) enable precise optical power levels;
- Display operation state and it's information;
- Front panel -20dB RF test port;
- Alarm for over operation ,low optical power output and communication
- Advanced high efficiency switching power supply to meet the AC voltage wide fluctuating (176V-264V);
- Reliable thermal structure design to ensure high stability and long operating life of the equipment.

3. M107E Technical Parameters:

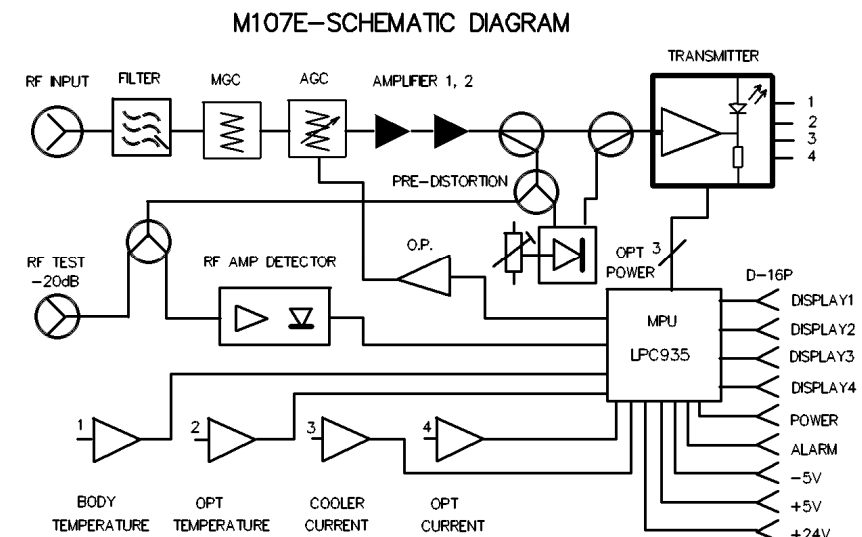

Parameters

	Item	Unit	Specification
1	Type of laser		DFB
2	Wavelength	nm	1310±20
3	Modulation mode		Direct Light Intensity Modulation
4	Output Optical Power	mw	8 10 12 14 16 18 20 22 24 26
5	Fiber Connector		FC/APC SC/APC
6	Frequency Range	MHz	45~930
7	Input RF Signal Level	dBmv	15~35
8	AGC range	dB	0~10 (MGC: 0~20dB)
9	CNR	dB	≥51 note
10	CTB	dB	≤-68 note
11	CSO	dB	≤-62 note
12	Flatness	dB	±0.75
13	RF Input Impedance	Ω	75
14	RF Input Return Loss	dB	≤-15
15	APC Control Precision	dB	≤±0.2
16	ATC Control Precision	℃	25±2
17	Max TEC Operating current	mA	DC+5V@850
18	MTBF	h	≥40000
19	Laser Operating Voltage Range	V	DC±4.5--±5.5
20	Laser Operating Temperature Range	℃	+5~+40
21	Overall Storage Temperature Range	℃	-25~55
22	Overall Relative Humidity	%	40~70
23	Overall Power Supply Input (with Filter)	V	AC220(176~264V)
24	Power Dissipation	W	15
25	Dimensions(WxDxH)	mm	210x160x40
26	Weight	Kg	1.75

Note: (Testing Condition):

Optical Link Loss: 10km Fiber + Optical Attenuator

RF Input: 59PAL-D/K Channels 47-550MHz, Input Optical Level: -1dBm

4. Order Information:

DIP state	Model	Rating LD Power
	M107E-4D	4mW(6dBm)
	M107E-8D	8mW(9dBm)
	M107E-10D	10mW(10dBm)
	M107E-12D	12mW(10.8dBm)
	M107E-14D	14mW(11.5dBm)
	M107E-16D	16mW(12dBm)
	M107E-18D	18mW(12.5dBm)
	M107E-20D	20mW(13dBm)
	M107E-22D	22mW(13.4dBm)
	M107E-24D	24mW(13.8dBm)
	M107E-26D	26mW(14.2dBm)

Optical Link Path C/N Parameter

Link Loss (dB) :	9	10	11	12	13	14	15	16	17	18	19
-08D	52.8	51.9	51.0	50.1	49.1	48.2					
-10D		52.9	51.9	51.0	50.1	49.1	48.2				
-12D			52.7	51.8	50.8	49.9	49.0	48.0			
-14D				52.4	51.5	50.5	49.5	48.6	47.8		
-16D					52.0	51.0	50.1	49.1	48.4		
-18D					52.5	51.6	50.6	49.7	48.7	47.9	
-20D					52.8	51.9	51.0	50.0	49.0	48.2	
-22D						52.2	51.3	50.4	49.4	48.4	
-24D							51.8	50.9	49.8	48.8	47.8
-26D								51.2	50.3	49.2	48.2

5. Appearance description (M107E as sample)

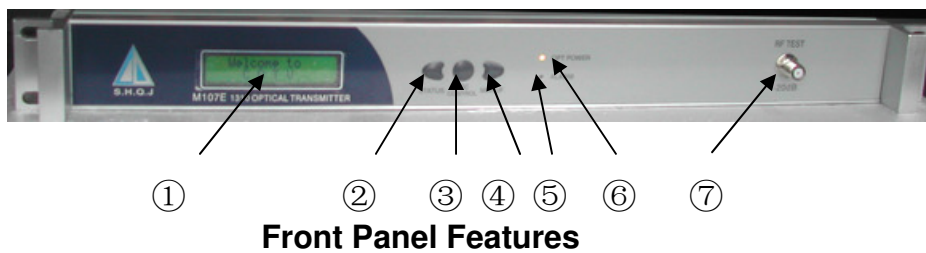

- ① **LCD:** Display operation states and its information each module;
- ② **Left Key:** Select operation states of module
- ③ **Middle Key:** AGC control to adjust the deeps of modulation, when selected using the left key and right key to decrees and increases the deeps of modulation
- ④ **Right Key:** Select information of module
- ⑤ **Laser LED:** Read- no laser, Green-Laser on;
- ⑥ **Alarm LED:** Flashing when operation state over usually and communication;
- ⑦ **RF test port :-** 2 0 d B RF level test port.

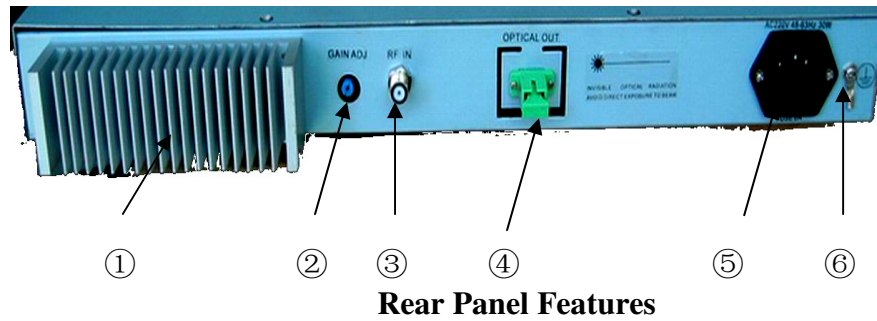

- ① **Radiator:**
- ② **RF Attenuator:** For suitable RF level (see 7.4)
- ③ **RF input:** The RF input level never higher than 50dBmV
- ④ **Optical signal output:** Interface SC/APC or FC/APC
- ⑤ **Power in:** To connect this unit to mains supply and using a fuse of 250V/1A
- ⑥ **Grounding screw**

6. Equipment Operations:

6.1. Display Explanations of LCD

- a; LCD displays 16 characters a line, totally two lines.
- b, Module/ Parameter name is in the first line;
Parameter value/Information is in the second line.
- c, Switch-on Character:
After plugging in to the suitable rack this set will automatically delay 5 seconds before open RF amplifier. Shows as follow:



6.2. Press middle key:

Change the amplitude of RF driving signal then change the modulation depth of the laser and can using the left key and right key to decrease and increases it.



Amplitude of RF



Amplifier working status

6.3. Operation Explanations of Left Key:

Press the left key, the following information will pop up:

1	Optical Power:	Optical output power
2(note1)	RF Driver:	Modulation of Laser
3	OPT Current:	Bias current of Laser
4	OPT Temperature:	Temperature of Laser
5	Cooler Current:	The current of cooler
6	DC +24V Test:	Test value of +24V
7	DC +5V:	Test value of+5V

Note1: If no RF signals it will display no RF signal as follow left finger. Otherwise LCD will display the amplitude of RF signal as follow right finger.

Totally 16 words >User may adjust the RF amplitude by pressing the left or right key (see 7.4) according to the number of TV channels transmitted and the parameters of your system to get a suitable modulation of the laser.



6.4. Operation Explanations of Right Key:

Press the right key, the following information will pop up:

1(note2)	Module: M107E-26D	Product model Option range
2	MANUF Date:	Date of leaving factory
3	Module SN:	Series number of module
4	Laser Type:	Series number of laser

7. Caution

- 7.1. When you get the transmitter check it, once you find any problem, please contact the product supplier as soon as possible.
- 7.2. The transmitter should be properly grounded.
- 7.3. The fiber SC/APC connector should be cleaned with absolute alcohol, to minimize the additional loss or reflection caused by dust, which will affect the specification. Connect the tail fiber to SC/APC socket on the rear panel, and keep the fiber hanging down.
- 7.4. Connect the mixed RF signal to F-port on the rear panel. The input level should be within a range of 15-35dBmV, on condition that the distortion specification is guaranteed. Though this equipment can automatically adjust the RF amplitude, but if the RF signal is higher than 35dBmV, you can adjust the attenuator on the rear panel to reduce the RF signal from zero to 20 dB to improve CNR. Local RF level can be tested from the -20dB port on front panel to get the actual operating RF amplitude.
- 7.5. If the laser runs well the green LED is on and will flash once a second, if it becoming red means the laser is out of work. The ALARM red LED will flash, if there is any fault in this unit. When the problem is being solved the transmitter will be operating normally.

8. Complete List

- | | |
|------------------|-----|
| a. Transmitter | one |
| b. Power-cord | one |
| c. User's Manual | one |